



## PS-121000 12V 100.0 AH @ 20-hr. 12V 95.2 AH @ 10-hr.

Rechargeable Sealed Lead Acid Battery  
PS Series - General Purpose

### TERMINALS: (mm)

**T6:** Threaded insert with 6mm stud fastener

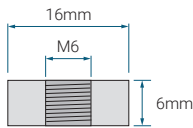

Torque: 3.9~5.4 Nxm

**U:** Universal terminals: Heavy-duty posts with 'nut & bolt' fasteners

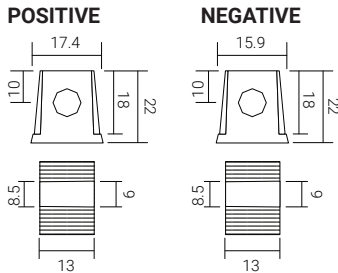

Torque: 11.0~14.7 Nxm

T6 Stocked in EU (Contact us for other terminal types)

### DIMENSIONS: inch (mm)

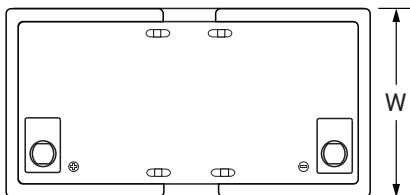

**L:** 12.05 (306)  
**W:** 6.61 (168)  
**H:** 8.19 (208)  
**TH:** 9.06 (230)

Tolerances are +/- 0.04 in. (+/- 1mm) and +/- 0.08 in. (+/- 2mm) for height dimensions. All data subject to change without notice.

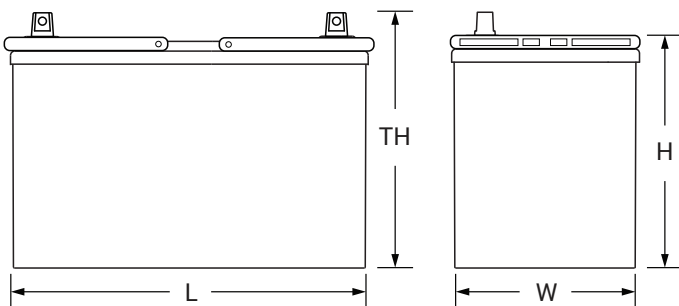

### GLOBAL HEADQUARTERS (USA AND INTERNATIONAL EXCLUDING EMEA)

The Power-Sonic Corporation  
365 Cabela Dr Suite 300,  
Reno, Nevada 89523  
USA  
T: +1 619 661 2020  
E: customer-service@power-sonic.com

### POWER-SONIC EMEA (EMEA – EUROPE, MIDDLE EAST AND AFRICA)

Power-Sonic EMEA  
Smitspol 4, 3861 RS, Nijkerk, Netherlands  
T NL: +31 33 7410 700  
T UK: +44 1268 560 686  
T FR: +33 344 32 18 17  
E: salesEMEA@power-sonic.com

### FEATURES

- Absorbent Glass Mat (AGM) technology for superior performance
- Valve regulated, maintenance-free spill proof construction
- Rugged vibration and impact resistant ABS case
- Power/volume ratio yielding excellent energy density
- Gas recombination technology
- Design life up to 10 years in standby mode

### APPROVALS

- Approved for transport by air. D.O.T., I.A.T.A., F.A.A. and C.A.B. certified
- UL 1989 Standard for Standby Batteries
- ISO9001:2015–Quality Management Systems
- IEC 60896-21/22 Stationary Lead-Acid Batteries
- EU 2023/1542 Compliant: European Battery Regulation

### PERFORMANCE SPECIFICATIONS

<b>Nominal Voltage</b>	12 volts (6 cells)
<b>Nominal Capacity</b>	
20-hr. (5.00A to 10.80 volts)	100.00 AH
10-hr. (9.50A to 10.80 volts)	95.00AH
5-hr. (18.000A to 9.60 volts)	90.00 AH
1-hr. (60.00A to 9.60 volts)	60.00 AH
<b>Approximate Weight</b>	67.46 lbs. (30.6 kg)
<b>Internal Resistance (approx.)</b>	5.8 milliohms
<b>Max Short-Duration Discharge Current (5 Sec.)</b>	1200.0 amperes
<b>Shelf Life</b> (% of nominal capacity at 68°F (20°C))	
1 Month	97%
3 Month	91%
6 Month	83%
<b>Operating Temperature Range</b>	
Charge	-4°F (-20°C) to 104°F (40°C)
Discharge	5°F (-15°C) to 122°F (50°C)
<b>Case</b>	ABS Plastic Rated to UL 94 H-B
<b>Power Sonic Chargers</b>	PSC-1210000A-C PSC-1210000-PC PSC-1220000-PC

## PS-121000 12V 100.0 AH @ 20-hr. 12V 95.2 AH @ 10-hr.

Rechargeable Sealed Lead Acid Battery  
PS Series - General Purpose

### FLOAT LIFE VS. TEMPERATURE

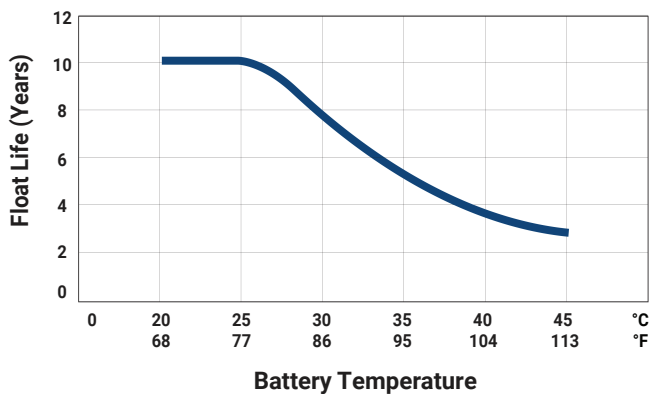

### GENERAL RELATION OF CAPACITY VS. STORAGE TIME

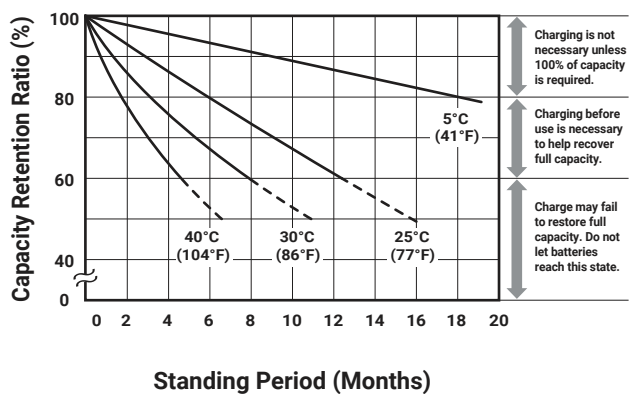

**Cycle Applications:** Apply constant voltage charge at 2.35VPC to 2.45VPC (14.1 to 14.7 volts for 12V Monobloc) at 20°C. The initial charging current should be set at less than C/5 Amps. Switch to float charge when the current falls to a 3% capacity rate to avoid overcharging.

**Stand-By or "Float" Service:** Apply constant voltage charge of 2.25VPC to 2.30VPC (13.5 to 13.8 volts for 12V Monobloc) at 20°C. When held at this voltage, the battery will seek its own current level and maintain itself in a fully charged condition.

**Temperature Compensation:** Charging voltage for both cyclic and stand-by applications should be regulated in relation to ambient temperature. As temperature rises, charging voltage should be reduced to prevent overcharge and increased as the temperature falls to avoid undercharge.

For further charging information, including temperature compensation factors, see the Power-Sonic Technical Manual.

### APPLICATIONS

- General purpose
- Medical
- Emergency lighting
- Fire and security

#### GLOBAL HEADQUARTERS (USA AND INTERNATIONAL EXCLUDING EMEA)

The Power-Sonic Corporation  
365 Cabela Dr Suite 300,  
Reno, Nevada 89523  
USA  
T: +1 619 661 2020  
E: customer-service@power-sonic.com

#### POWER-SONIC EMEA (EMEA – EUROPE, MIDDLE EAST AND AFRICA)

Power-Sonic EMEA  
Smitspol 4, 3861 RS, Nijkerk, Netherlands  
T NL: +31 33 7410 700  
T UK: +44 1268 560 686  
T FR: +33 344 32 18 17  
E: salesEMEA@power-sonic.com

Power Sonic offers a wide range of chargers suitable for batteries with a variety of capacities.

Please refer to our website for more information on our switch mode and transformer type chargers.

Please contact our technical department for advice if you have difficulty in locating a suitable charger.

### FURTHER INFORMATION

Please refer to our website [www.power-sonic.com](http://www.power-sonic.com) for a complete range of useful downloads, such as product catalogs, material safety data sheets (MSDS), ISO certification, etc.

