



PS-6120 6V 13.0 AH @ 20-hr. 6V 12.3 AH @ 10-hr.

Rechargeable Sealed Lead Acid Battery
PS Series – General Purpose

TERMINALS: (mm)

F1: Quick disconnect tabs,
0.187" x 0.032" – Mate with
AMP. INC. FASTON "187" series

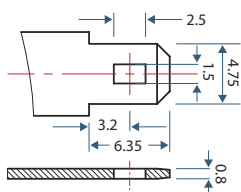

Torque – Not Applicable

F1 Stocked in EU (Contact us for other terminal types)

DIMENSIONS: inch (mm)

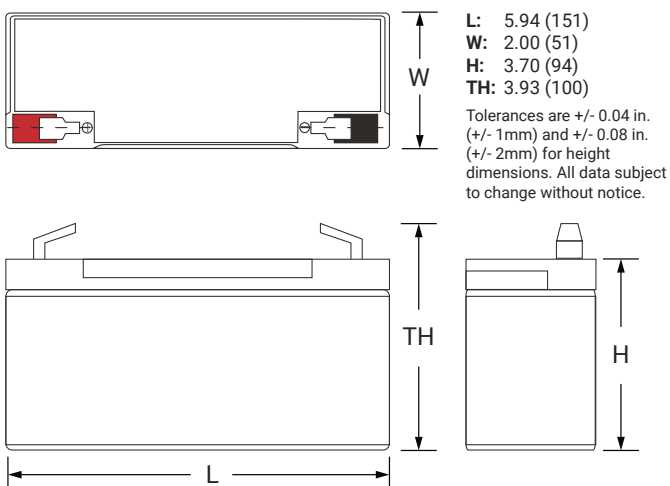

FEATURES

- Absorbent Glass Mat (AGM) technology for superior performance
- Valve regulated, maintenance-free spill proof construction
- Rugged vibration and impact resistant ABS case
- Power/volume ratio yielding excellent energy density
- Gas recombination technology
- Design life of 3-5 years in standby mode

APPROVALS

- Approved for transport by air. D.O.T., I.A.T.A., F.A.A. and C.A.B. certified
- UL 1989 Standard for Standby Batteries
- ISO9001:2015–Quality Management Systems
- IEC 60896-21/22 Stationary Lead-Acid Batteries
- EU 2023/1542 Compliant: European Battery Regulation

PERFORMANCE SPECIFICATIONS

Nominal Voltage	6 volts (3 cells)
Nominal Capacity	
20-hr. (550mA to 5.25 volts)	13.00 AH
10-hr. (1.23A to 5.25 volts)	12.30 AH
5-hr. (2.17A to 4.80 volts)	10.85 AH
1-hr. (7.49A to 4.80 volts)	7.49 AH
Approximate Weight	4.41 lbs. (2.00 kg)
Internal Resistance (approx.)	14.0 milliohms
Max Short-Duration Discharge Current (10 Sec.)	120.0 amperes
Shelf Life (% of nominal capacity at 68°F (20°C))	
1 Month	97%
3 Month	91%
6 Month	83%
Operating Temperature Range	
Charge	-4°F (-20°C) to 104°F (40°C)
Discharge	5°F (-15°C) to 122°F (50°C)
Case	ABS Plastic Rated to UL94:HB
Power Sonic Chargers	PSC-61000ACX

GLOBAL HEADQUARTERS (USA AND INTERNATIONAL EXCLUDING EMEA)

The Power-Sonic Corporation
365 Cabela Dr Suite 300,
Reno, Nevada 89523
USA
T: +1 619 661 2020
E: customer-service@power-sonic.com

POWER-SONIC EMEA (EMEA – EUROPE, MIDDLE EAST AND AFRICA)

Power-Sonic EMEA
Smitspol 4, 3861 RS, Nijkerk, Netherlands
T NL: +31 33 7410 700
T UK: +44 1268 560 686
T FR: +33 344 32 18 17
E: salesEMEA@power-sonic.com

PS-6120 6V 13.0 AH @ 20-hr. 6V 12.3 AH @ 10-hr.

Rechargeable Sealed Lead Acid Battery PS Series – General Purpose

FLOAT LIFE VS. TEMPERATURE

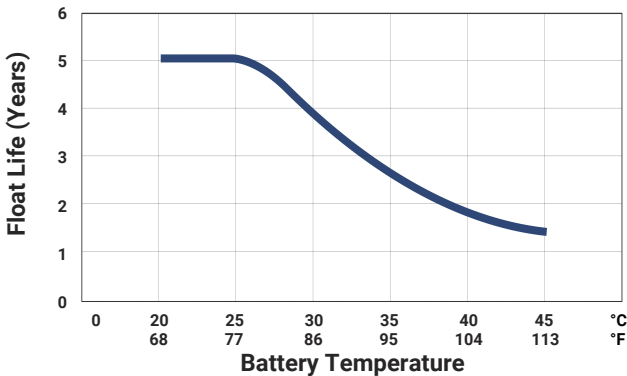

GENERAL RELATION OF CAPACITY VS. STORAGE TIME

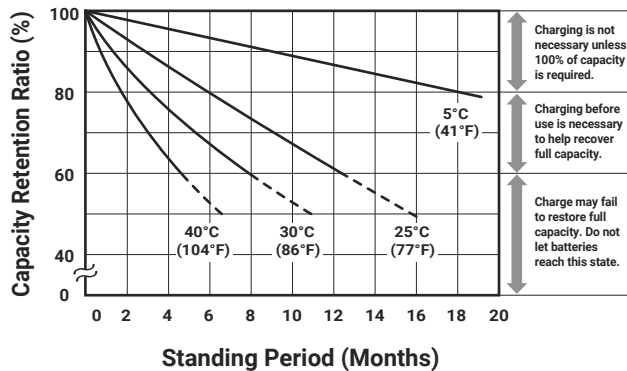

CHARGING

Cycle Applications: Apply constant voltage charge at 2.35VPC to 2.45VPC (14.1 to 14.7 volts for 12V Monobloc) at 20°C. The initial charging current should be set at less than C/5 Amps. Switch to float charge when the current falls to a 3% capacity rate to avoid overcharging.

Stand-By or "Float" Service: Apply constant voltage charge of 2.25VPC to 2.30VPC (13.5 to 13.8 volts for 12V Monobloc) at 20°C. When held at this voltage, the battery will seek its own current level and maintain itself in a fully charged condition.

Temperature Compensation: Charging voltage for both cyclic and stand-by applications should be regulated in relation to ambient temperature. As temperature rises, charging voltage should be reduced to prevent overcharge and increased as the temperature falls to avoid undercharge.

For further charging information, including temperature compensation factors, see the Power-Sonic Technical Manual.

APPLICATIONS

- General purpose
- Medical
- Emergency lighting
- Fire and security

GLOBAL HEADQUARTERS (USA AND INTERNATIONAL EXCLUDING EMEA)

The Power-Sonic Corporation
365 Cabela Dr Suite 300,
Reno, Nevada 89523
USA
T: +1 619 661 2020
E: customer-service@power-sonic.com

POWER-SONIC EMEA (EMEA – EUROPE, MIDDLE EAST AND AFRICA)

Power-Sonic EMEA
Smitspol 4, 3861 RS, Nijkerk, Netherlands
T NL: +31 33 7410 700
T UK: +44 1268 560 686
T FR: +33 344 32 18 17
E: salesEMEA@power-sonic.com

CHARGERS

Power Sonic offers a wide range of chargers suitable for batteries with a variety of capacities.

Please refer to our website for more information on our switch mode and transformer type chargers.

Please contact our technical department for advice if you have difficulty in locating a suitable charger.

FURTHER INFORMATION

Please refer to our website www.power-sonic.com for a complete range of useful downloads, such as product catalogs, material safety data sheets (MSDS), ISO certification, etc.

